

# KL32

ON A LIGHT COMMERCIAL VEHICLE



Working height

## SPECIFICATIONS



12.5m



7.3m

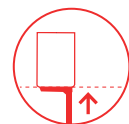

10.5m



360°



120 kg



No outriggers



86 x 72  
x 110 cm



≤ 3.5 t



# AERIAL PLATFORM

## ON A LIGHT COMMERCIAL VEHICLE

### COMPATIBLE CARRIER VEHICLES

- RENAULT MASTER L2H2
- PEUGEOT BOXER L2H2
- CITROËN JUMPER L2H2
- IVECO DAILY VAN

*For other carrier vehicles, please contact our sales department.*

### WORKING DIAGRAM

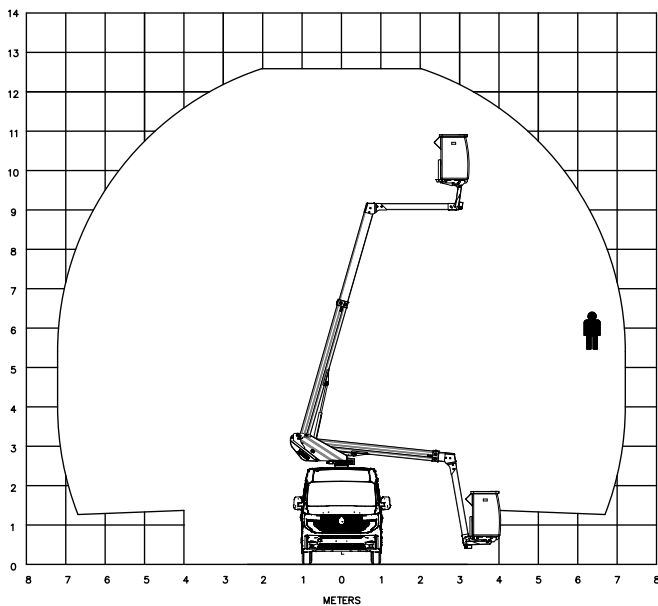

### VEHICLE DRAWING

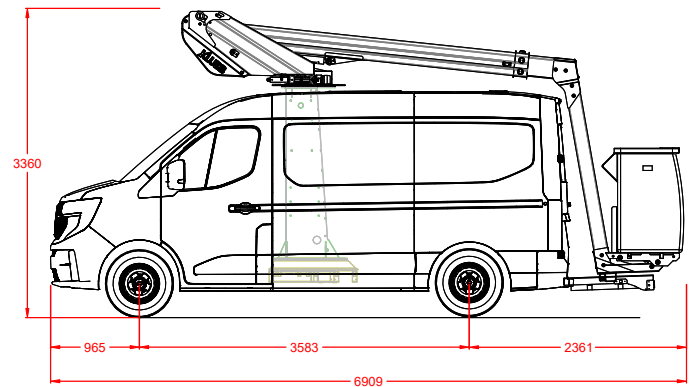

### STANDARD SPECIFICATIONS

- Engine start/stop from platform
- Emergency circuit on independent electric pump with all functions from platform for maximum safety
- Proportional controls on all movements
- Secure access to working platform
- Hose carrier chain inside mast for optimum protection
- Upper mast in aluminium for maximum stability

### OPTIONS

- 2-person basket (200 kg) with stabilisers and basket controls
- Signalling (tri-flash, 2 flashing beacons, chevrons)
- 220V electrical system in platform
- Heavy-duty suspension
- Low-voltage insulated full-opening basket
- Interior fittings
- Internal/external side ladder rack
- Green Pack: battery-powered platform operation with engine off

*For other options, please contact our sales department.*



Request a demonstration